



Gunclean Toftejorg i40 S

Single-nozzle tank cleaning machine

Alfa Laval's single-nozzle Gunclean Toftejorg i40 S is a second-generation high-impact, fully programmable tank cleaning machine. Developed to meet the toughest tank cleaning requirements, it features a hysteresis clutch with built-in speed adjustment.

This innovative clutch construction not only eliminates shaft penetration between the turbine and gearbox, but also prevents slippage and false starts. In combination with optimized design and new, wear-resistant materials, it makes the Gunclean Toftejorg i40 S a simple and reliable choice for cost-effective operation.

Application

The Gunclean Toftejorg i40 S is designed for use in fixed installations aboard chemical and product carriers as well as in offshore applications. Its reliable operation and wear-resistant design make it suitable for use in all types of tank cleaning applications. With a required deck opening of only 145 mm, the i40 S machine is the optimal machine for upgrading older tank cleaning machines on chemical tankers.



Features and benefits

Hysteresis clutch

The patented clutch of the Gunclean Toftejorg i40 S, which comprises a hysteresis plate on one side and supermagnets on the other, eliminates shaft penetration between the turbine and gearbox. Unlike a standard magnetic clutch, in which two opposing magnets must be synchronized, it will not slip during water hammering – thus eliminating false starts. The clutch works as a soft starter, making sure that the tank cleaning machine always begins to operate.

Easy speed adjustment

The nozzles are factory preset with a standard rotational speed that is applicable for most cleaning operations. To change the preset speed, adjust the magnetic brake to regulate nozzle rotation. Simply remove the gearbox cover to access the magnet, then increase or decrease the distance between the magnet and the hysteresis plate to slow or accelerate rotation.

No speed adjustment shaft

The patented hysteresis clutch does away with speed adjustment at the turbine. This removes the need for shaft penetration on the turbine side, eliminating a potential source of seal leakage and cross-contamination.

Optimized turbine

The turbine of the Gunclean Toftejorg i40 S is specially designed for better power transmission, which contributes to increased machine lifetime.

High-tech ceramics

Balls of high-tech, wear-resistant ceramics have been used in the turbine construction. These reduce friction in the gear system and reduce the consumption of spare parts.

Isolated gearbox

The oil-free gearbox is located above deck and can be removed without exposing the tank to the atmosphere. This facilitates service.

Robust construction

The gearbox has a stronger construction than previous tank cleaning machines and involves fewer wear parts.

Cleaning patterns

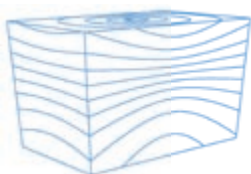

Coarse pattern

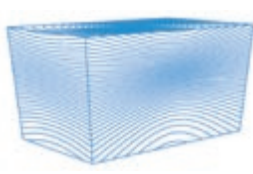

Dense pattern

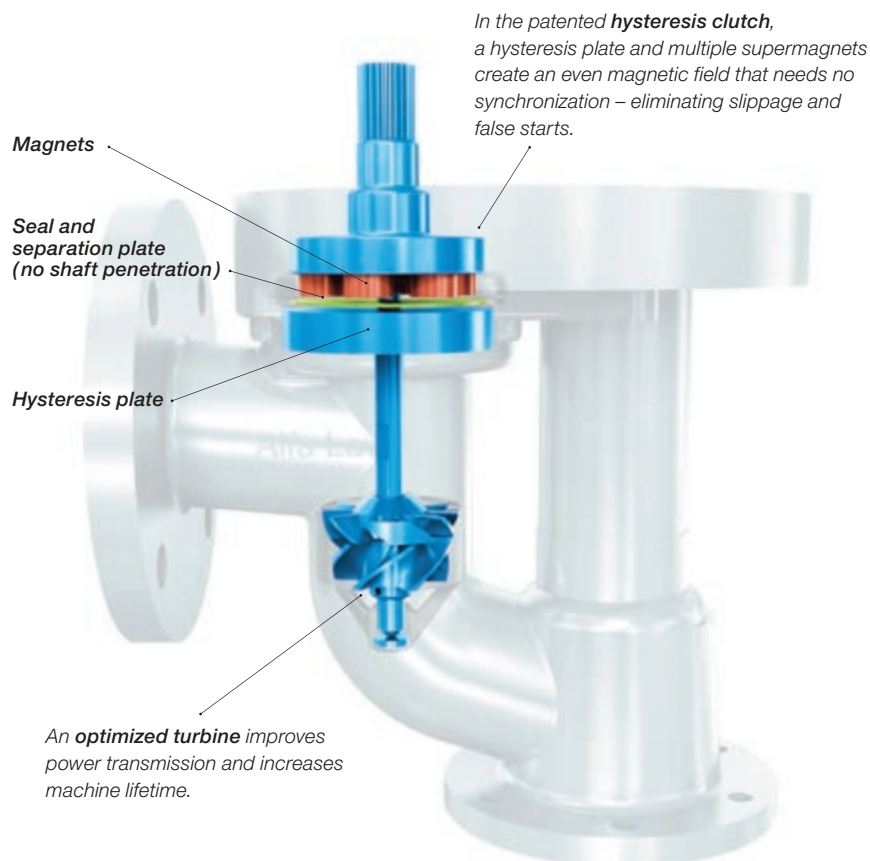

Operation

A flow of cleaning media or product is used to drive a turbine connected to the Gunclean Toftejorg i40 S gear unit. This drives the cleaning head horizontally while the nozzle moves vertically, which directs the cleaning media in a helical cleaning pattern.

The current nozzle position and degree of rotation are indicated at all times. Both pitch angle and rotation speed can be adjusted during operation, thus making it possible to optimize the cleaning cycle.

Options

- Deck and inlet flange with customized dimensions
- 2" ball valve with strainer and CAM lock coupling (male) with dust cap
- Sensor connection for all cargo control systems
- Multi-level installation
- Split pipe

Regulations

The Gunclean Toftejorg i40 S is fully compliant with IMO regulations and the requirements of the classification societies.

Specifications

Materials, main parts	AISI 316 as standard
Sealings	Oil, product and chemical resistant
Lubricant	Grease
Working pressure	4–12 bar
Max. working temperature	0–95°C (32–203°F)
Capacity	3–56 m ³ /h
Effective design jet length	Up to 40 m
Programmability	4 cleaning programs
Sealings	
Inert gas	0–0.7 bar (0–10 psi)
Cleaning fluid	0–12 bar (0–174 psi)

Gunclean Toftejorg i40 S with inlet flange

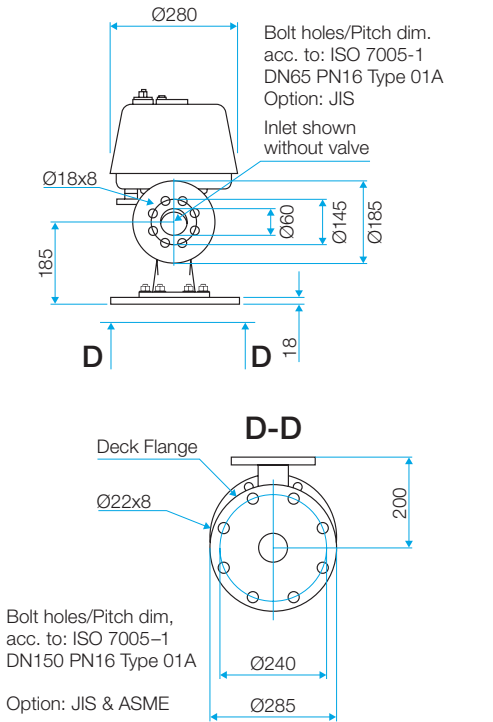

Deck opening
min. Ø145

Gunclean Toftejorg i40 S with inlet ball valve

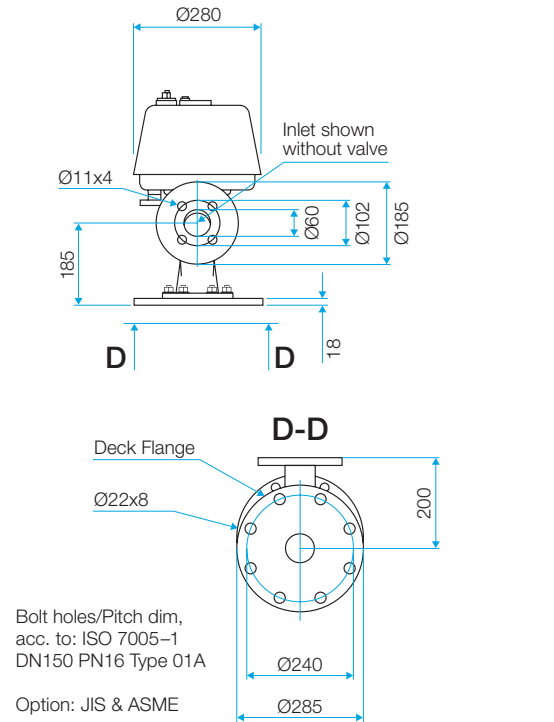

Deck opening
min. Ø145

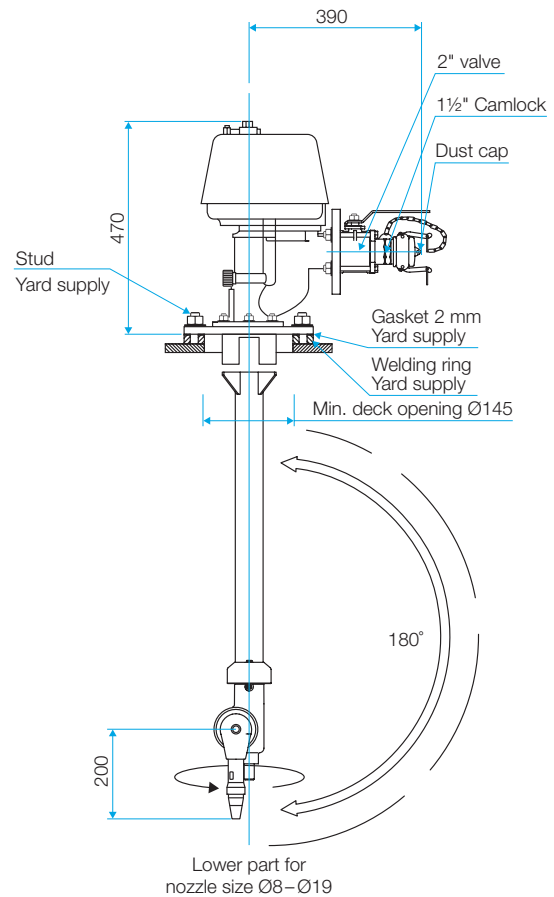
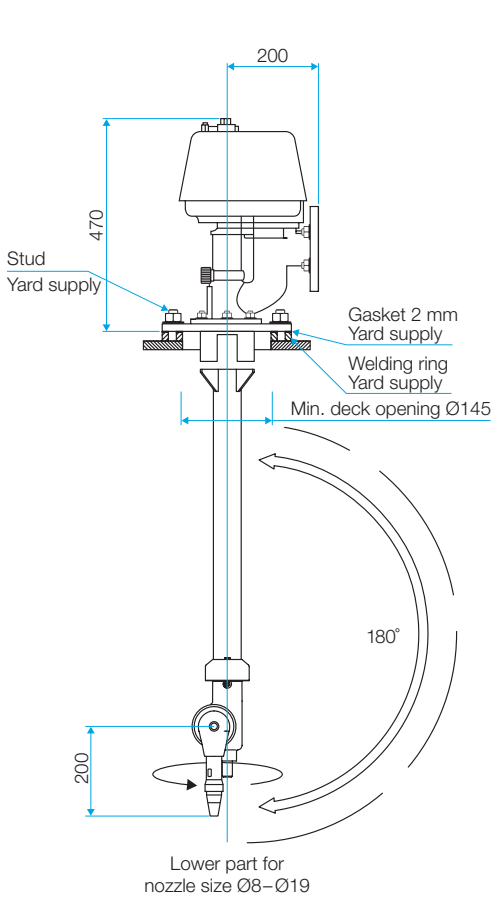

All dimensions shown in mm unless otherwise noted.

Performance diagram Design Throw Length
Alfa Laval Type: Gunclean Toftejorg i40S

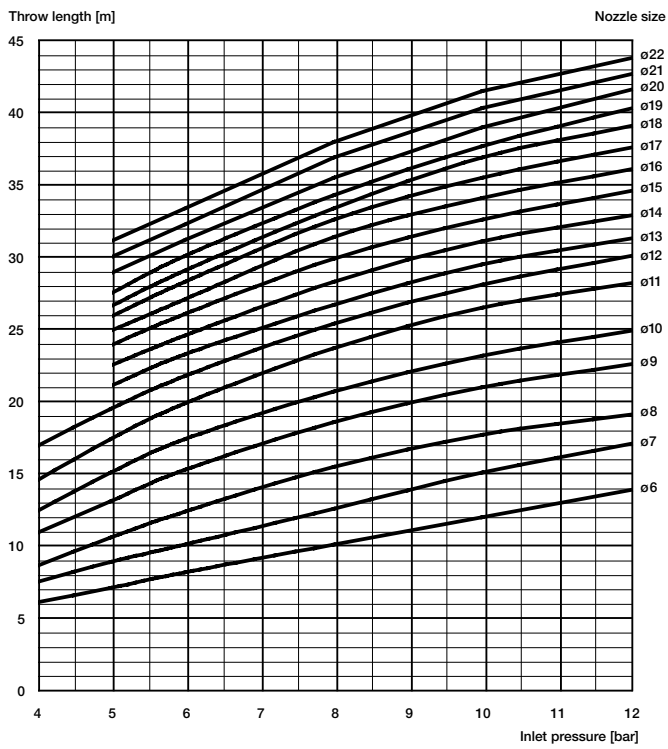

Performance diagram Flow Rate
Alfa Laval Type: Gunclean Toftejorg i40S

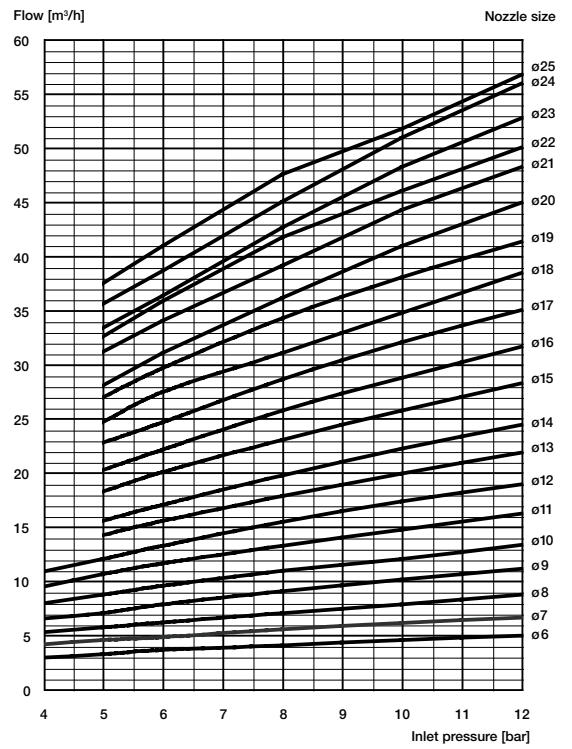

EMD00210EN 1001

Alfa Laval reserves the right to change specifications without prior notification.

How to contact Alfa Laval

Contact details for all countries are continually updated on our web site. Please visit www.alfalaval.com/marine to access the information direct.