

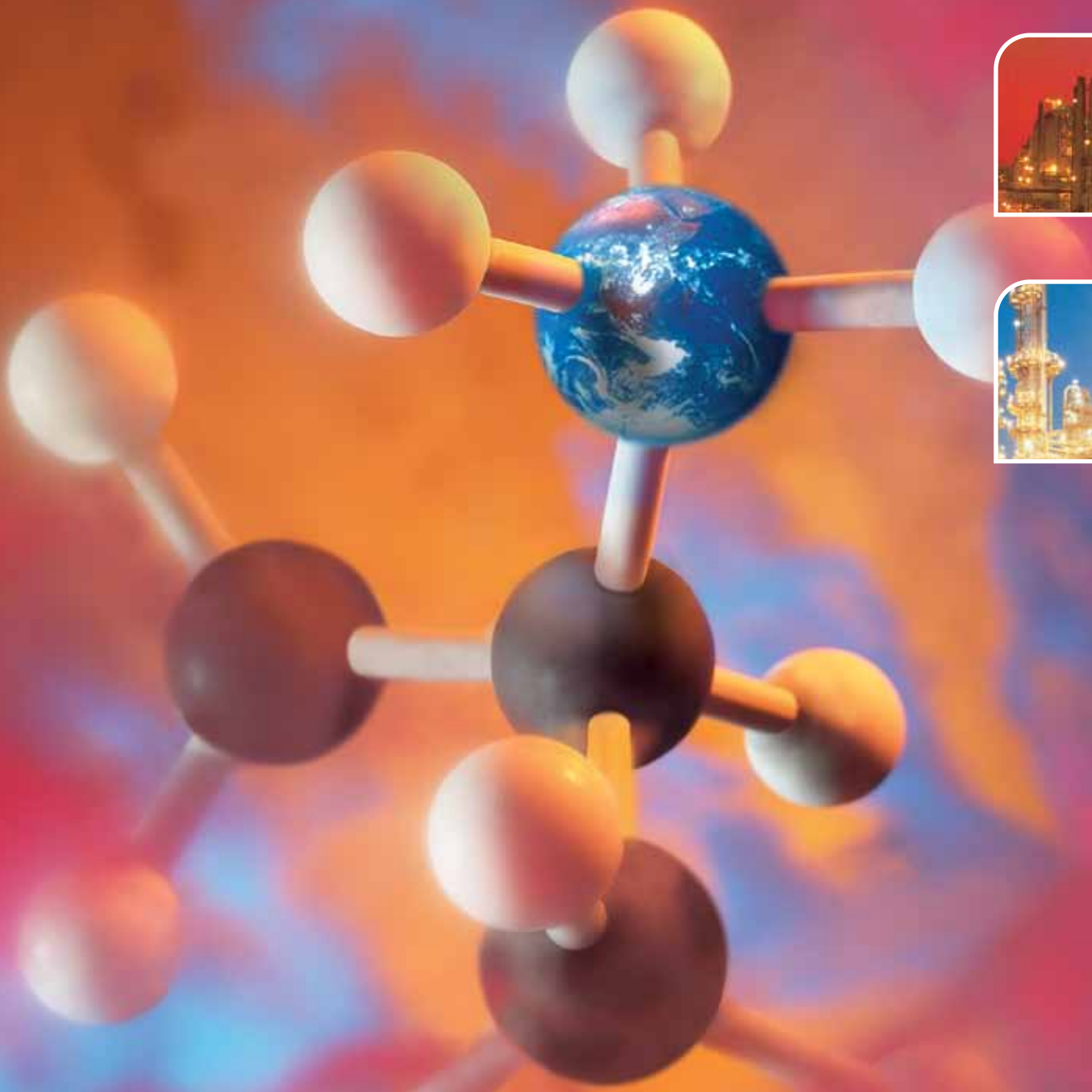

Hydrocarbon Processing Pumps

Refining • Petrochemical Processing



Experience In Motion



Pump Supplier to the World

Flowserve is the driving force in the global industrial pump marketplace. No other pump company in the world has the depth or breadth of expertise in the successful application of pre-engineered, engineered, and special purpose pumps and systems.

Supplier of Choice to the Hydrocarbon Processing Industry

Flowserve offers the world's most complete line of API 610 pumps with the widest range of hydraulic coverage, pressure and temperature capabilities. Its engineering expertise, applications know-how and installation experience are peerless. From 19th century lamp oil to the advent of the gasoline engine and the development of petrochemicals, Flowserve has proven itself to be the world leader in meeting the changing and demanding needs of hydrocarbon processing.



Product Brands of Distinction

- ACEC™ Centrifugal Pumps*
- Aldrich™ Pumps*
- Byron Jackson® Pumps*
- Calder™ Energy Recovery Devices*
- Cameron™ Pumps*
- Durco® Process Pumps*
- Flowserve® Pumps*
- IDP® Pumps*
- Lawrence Pumps®*
- Niigata Worthington™ Pumps*
- Pacific® Pumps*
- Pleuger® Pumps*
- Scienco™ Pumps*
- Sier-Bath® Rotary Pumps*
- TKL™ Pumps*
- United Centrifugal® Pumps*
- Western Land Roller™ Irrigation Pumps*
- Wilson-Snyder® Pumps*
- Worthington® Pumps*
- Worthington Simpson™ Pumps*



Pump Designs

Flowserve offers a wide range of complementary pump types, built to recognized global standards and customer specification. These include:

- Single-stage process
- Between bearing single-stage
- Between bearing multistage
- Vertical
- Submersible motor
- Positive displacement
- Nuclear
- Specialty

Available Configurations

- Sealed and sealless
- Axially and radially split
- Volute and diffuser
- Close coupled and long coupled
- Single and double casing



Committed to the Complete Pump System Life Cycle

For more than two centuries, Flowserve has served industries requiring solutions that add value and reduce costs throughout the life cycle of a pumping system.

- Oil and gas
- Power generation
- Chemical
- Water
- General industry

Flowserve partners with customers to respond to the dynamic business conditions that affect them. Flowserve works with customers to improve efficiency, maximize throughput and control process quality. Whether customer needs involve on-site technical assistance, equipment upgrades or broader project planning with full turnkey responsibility, Flowserve delivers professional, reliable results.





Refining

Sophisticated process technology along with advanced equipment and materials engineering make possible the conversion of feedstocks into fuel for transportation, fertilizers for agriculture and products for everyday life. And to no small extent, it is the resourcefulness of Flowserve that turns the technologically possible into practical solutions.

Throughout the years, Flowserve has pioneered off-the-shelf and purpose-engineered designs in a wide array of materials to safely and reliably handle any kind of process liquid at all encountered pressures and temperatures.



Playing a Key Role

A contributing member on the API 610, API 676 and API 682 committees, Flowserve is in the forefront of meeting the hydrocarbon processing industry's ever increasing need for improved safety, reliability and emissions containment. Equally important, Flowserve provides the flexibility to readily handle different crude types and intermediate stream qualities in virtually all charge, process, transfer and storage applications as well as address service and utility needs.

With more than a hundred different ISO 13709/API 610 pump models, each available with multiple hydraulic and mechanical configurations, Flowserve can efficiently and cost effectively address the widely diverse pumping applications in a refinery. These include all aspects of production for reformulated gasoline (RFG), alternative transportation fuels (ATFs), gas-to-liquid conversion (GTL) and synthetic fuels from tar sands as well as pumps for the more routine yet equally difficult processes and liquids.

Leading the Pump Industry

As the global leader in pump design and engineering for the hydrocarbon processing industry, Flowserve plays a major role in the practical implementation of new and improved process technologies. Flowserve accomplishes this through a continuous commitment to research and technology and by its leadership in these important industry organizations and committees:

- API
- ASME
- ASTM
- Europump
- HI
- ISO
- NACE
- NFPA





Petrochemical Processing

Safety, reliability and emission containment are top priorities for hydrocarbon processing operations. Improved equipment mean time between failure and lower total life cycle cost, likewise, are issues of continuing urgency.

Compared to refining, petrochemical processing involves lower operating pressures and temperatures but often with significantly more corrosive liquids. Flowserve leads the hydrocarbon pumping industry in large part due to its alloy expertise and applications know-how. This has a significant and positive impact on pump safety and reliability.



From Handling Primaries and Intermediaries to Transferring Feedstocks

Pumps for the hydrocarbon processing industry handle liquids that are volatile, flammable and sometimes toxic. Containment of these liquids is a central aspect of pump and seal selection. The combination of pump types available from Flowserve ensures compliance with global emission laws and regulations.

Flowserve provides the petrochemical processing industry with the most complete lines of chemical and process pumps available. Chemical pumps meet ASME (ANSI) B73.1M or ISO 2858 with ISO 5199 design criteria; process pumps, ISO 13709/API 610.

Global Alliances, Support and Service

As measure of its leadership in the hydrocarbon processing industry, Flowserve maintains strategic alliances with the world's most prominent energy companies. While typically these relationships are global, they may include more limited and localized project partnerships and service agreements.





Special Purpose Pumps and Systems

Without question, Flowserve offers the industry's most extensive line of API 610 pumps for virtually all applications in separation, conversion and treatment. Further attesting to its capabilities, Flowserve has been a leader in the development of more specialized, even unique pumps for proprietary processes and advanced process technologies. These special purpose pumps include:

- Cryogenic liquid expanders to increase LNG production
- Unspared process double casing pumps for reactor charge
- Hydraulic power recovery turbines
- Reactor circulating systems for ebullated catalyst bed hydrocrackers
- Slurry pumps of special materials for handling abrasive bottoms
- Hydraulic decoking systems used in delayed cokers
- Horizontal and vertical cryogenic pumps
- Zirconium pumps for proprietary processes
- High suction pressure designs for GTL processes



TKW Cryogenic Liquid Expanders

LNG production is typically a two-stage refrigeration process: vapor compression, then liquid expansion. Expanding the mixed refrigerant and LNG across an expander instead of a valve improves the thermal performance of the process. The result is greater LNG production, up to 4%, for the same compression effort.

The Flowserve type TKW cryogenic expander, introduced in 1989, is a multistage, fixed or variable geometry, fixed speed turbine loaded by a generator. There are now more than 15 units in service.

Type PR Reactor Recycle (Ebullating) and Recirculation Boosting Systems

Ebullated catalyst bed hydrocrackers offer improved conversion of heavy oils, residues and coal slurries. A reactor recycle system, ebullating pump plus variable frequency drive and oil injection pump, ebullates the catalyst bed.

The type PR pump is also used in distillate hydrocracking processes where a pressure boost is required between reactor vessels. The unspared pump operates at reactor conditions, pressures to 210 bar (3000 psi), temperatures to 480°C (900°F), and must run three years or more between inspections.

Flowserve developed the first PR ebullating pump in 1965 and now has more than 60 units in service.

Hydraulic Decoking Systems

Delayed coking is a thermal cracking process widely used to reduce heavy bottoms to valuable volatiles and petroleum coke. The coke is formed in drums and removed using a hydraulic decoking system.

Hydraulic decoking employs high velocity water jets, produced by the decoking tool from water at pressures up to 415 bar (6000 psi). A special purpose double casing pump, rated up to 3500 kW (4700 hp), supplies the high-pressure water. Safe and effective decoking is assured by a custom control system.

Since hydraulic decoking was developed in 1938, Flowserve has furnished more than 180 decoking systems. Today, Flowserve maintains a leadership role with innovative products, like the AutoShift™ cutting tool, that continuously improve the safety and efficiency of the decoking process.



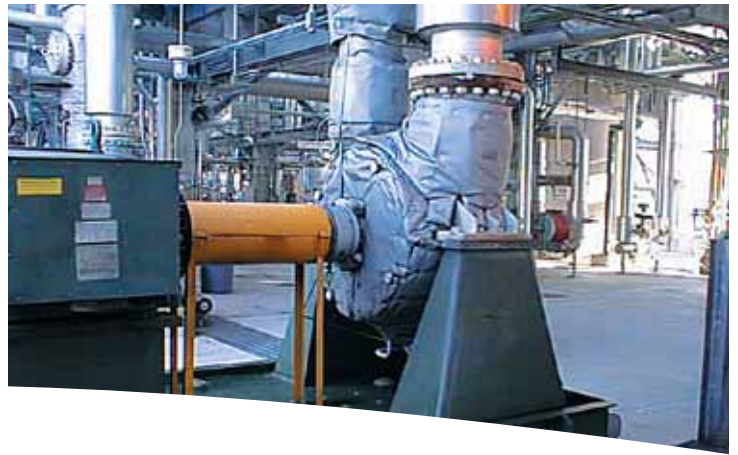

Process Pumps

Flowserve hydrocarbon processing pumps comply with the latest applicable industry standards.

- Charge-feed — Horizontal multistage, single or double casing
- Process — API, ANSI or ISO overhung process; two-stage process; horizontal multistage
- Transfer and storage — Horizontal and vertical, single or multistage
- Service and utility — Horizontal single or multistage; vertical turbine; vertical circulator; vertical sump

Two-Stage, Between Bearings, Radially Split Pumps

(API-BB2)

Horizontal, two-stage, single-suction opposed impellers for medium head, high-temperature services. Double-suction, first-stage impeller available for low NPSHA/high flow services. Available with coke crusher design

Operating Parameters

- Flows to 1360 m³/h (6000 gpm)
- Heads to 690 m (2250 ft)
- Temperatures to 450°C (850°F)
- Pressures to 100 bar (1500 psi)

Single-Stage, Between Bearings, Radially Split Pumps

(API-BB2)

Horizontal, double-suction pumps for use in critical services and low NPSHA applications. Available with coke crusher design

Operating Parameters

- Flows to 4100 m³/h (18 000 gpm)
- Heads to 450 m (1500 ft)
- Temperatures to 450°C (850°F)
- Pressures to 100 bar (1500 psi)

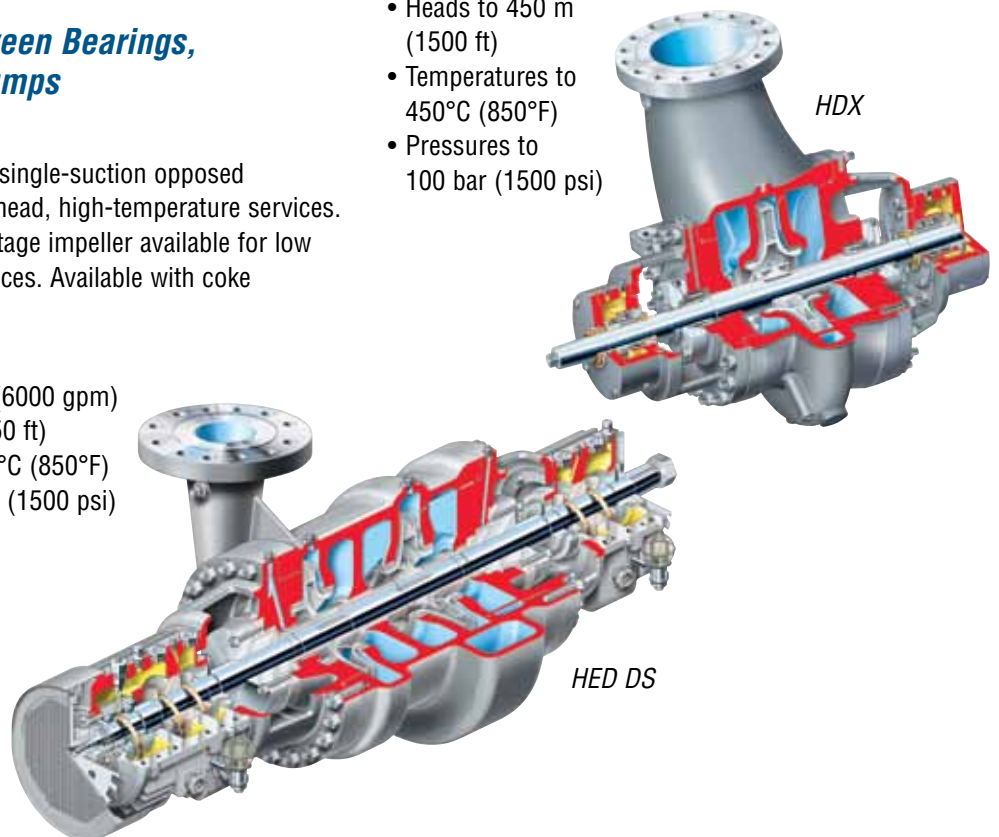



Single-Stage, Overhung, API Process Pumps

(API-OH2, API-OH3, API-OH4, API-OH5)

Horizontal and vertical in-line configurations. Fully compliant with API 610, latest edition for refinery and petrochemical plant services. Available with inducers for low NPSH requirements. Available with coke crusher design

Operating Parameters

- Flows to 2050 m³/h (9000 gpm)
- Heads to 335 m (1100 ft)
- Temperatures to 450°C (850°F)
- Pressures to 80 bar (1160 psi)

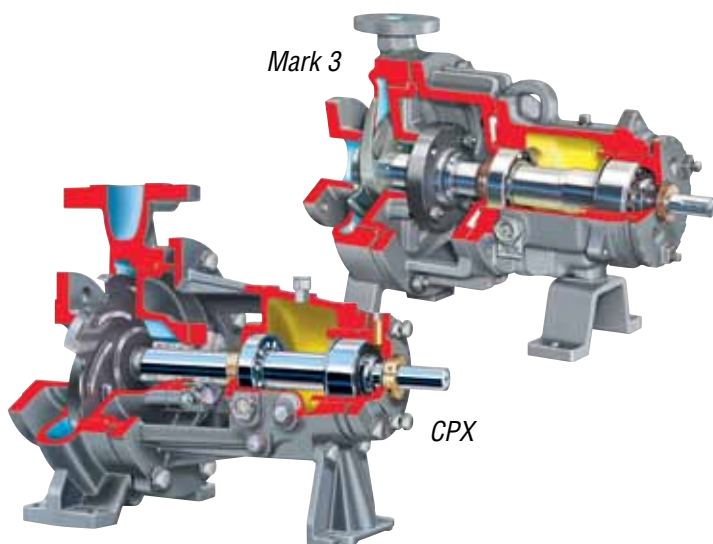
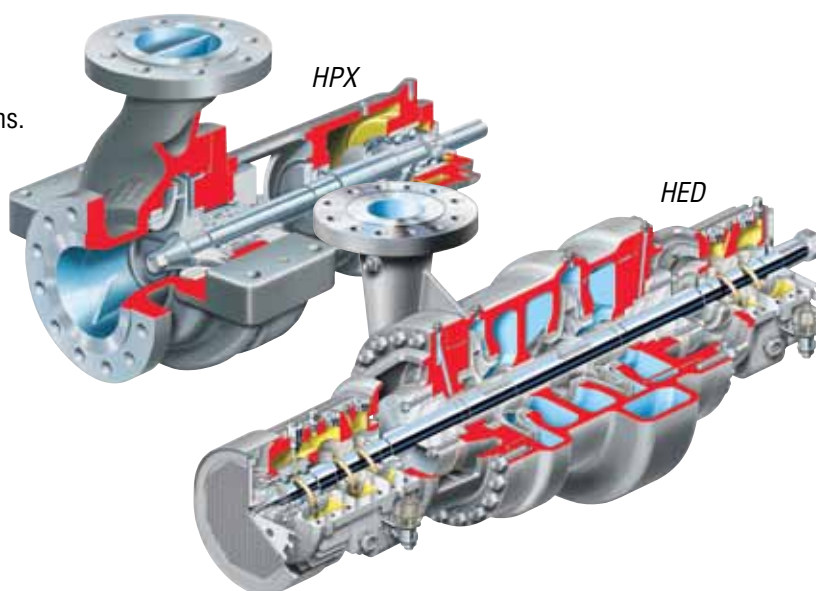

ANSI and ISO Chemical Process Pumps

Chemical Pumps

Pumps conform to the ASME B73.1M (ANSI) standard or to ISO 2858 dimensional with ISO 5199 design criteria. Shaft sealed and sealless models available

Operating Parameters

- Flows to 1680 m³/h (7400 gpm)
- Heads to 300 m (985 ft)



Tank Farm, Storage and Transfer Pumps

Single- and Two-Stage, Axially Split Pumps

(API-BB1)

Axially split, double volute case, double-suction pumps for transfer service and related heavy-duty requirements

Operating Parameters

- Flows to 22 700 m³/h (100 000 gpm)
- Heads to 685 m (2250 ft)
- Pressures to 83 bar (1200 psi)
- Temperatures to 200°C (400°F)
- Speeds to 4200 rpm

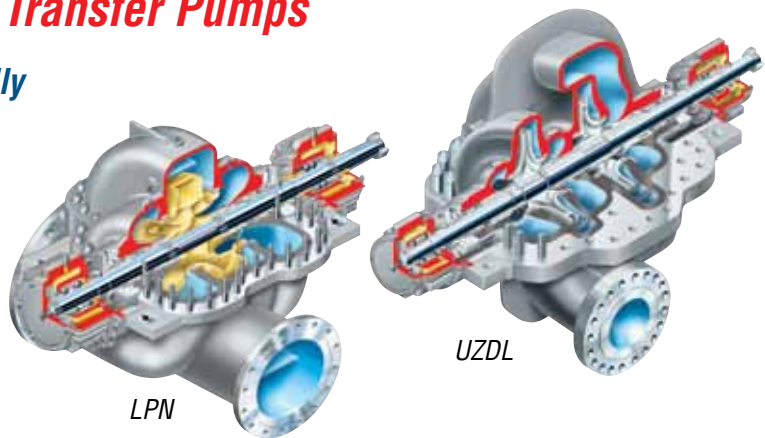

Vertical Turbine, Double Casing Pumps

(API-VS6)

High-pressure, heavy-duty diffuser type, single or multistage pump for continuous duty in hydrocarbon booster and transfer services. Available with single- or double-suction, first-stage impeller

Operating Parameters

- Flows to 13 600 m³/h (60 000 gpm)
- Heads to 1100 m (3500 ft)
- Pressures to 100 bar (1500 psi)
- Temperatures from -185°C (-300°F) to 230°C (450°F)



Vertical, In-line Diffuser Pumps

(API-OH3)

Vertical, in-line diffuser process pump with bearing housing features precision-machined and interchangeable diffuser channels customized to make virtually any specific duty conditions the hydraulic best efficiency point.

Operating Parameters

- Flows to 500 m³/h (2200 gpm)
- Heads to 275 m (900 ft)
- Pressures to 40 bar (600 psi)
- Temperatures to 250°C (480°F)

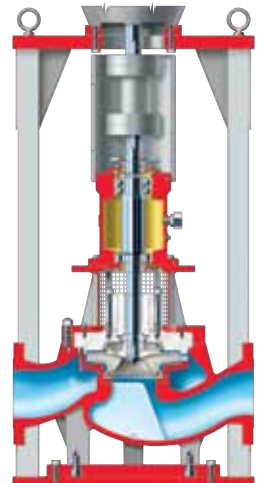

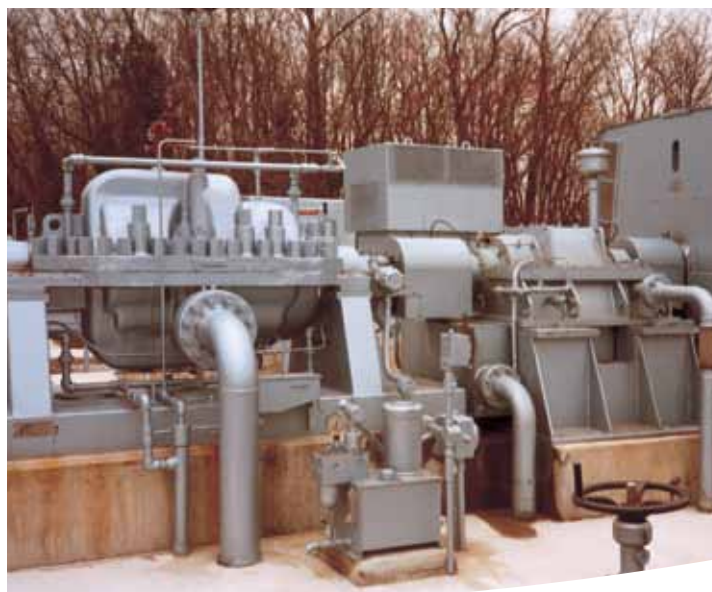

Charge and Specialty Applications

Multistage, Axially Split Pumps

(API-BB3)

Between bearings, axially split, double volute case, side suction, side discharge, multistage design. For high-pressure, heavy-duty applications

Operating Parameters

- Flows to 2875 m³/h (10 000 gpm)
- Heads to 2150 m (7000 ft)
- Pressures to 275 bar (4000 psi)
- Temperatures to 205°C (400°F)

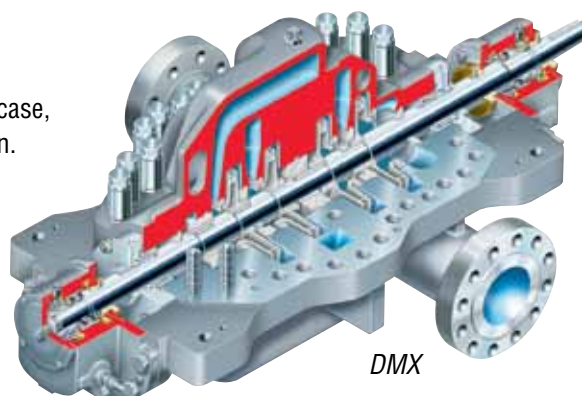

Horizontal, Multistage, Double Casing Pumps

(API-BB5)

Diffuser or volute type pumps for high-pressure service. First-stage single- or double-suction, depending on available NPSH. Designs for both general purpose (spared) and special purpose (unspared) applications

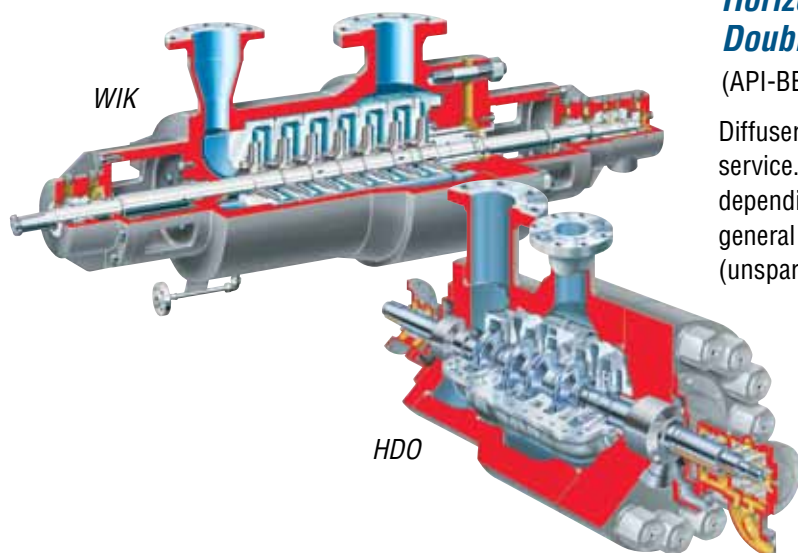

Operating Parameters

- Flows to 2875 m³/h (10 000 gpm)
- Heads to 6700 m (22 000 ft)
- Pressures to 415 bar (6000 psi)
- Temperatures to 450°C (850°F)



Life Cycle Cost Solutions

Typically, 90% of the total life cycle cost (LCC) of a pumping system is accumulated after the equipment is purchased and installed. Flowserve has developed a comprehensive suite of solutions aimed at providing customers with unprecedented value and cost savings throughout the life span of the pumping system. These solutions account for every facet of life cycle cost, including:

- Capital Expenses
 - Initial purchase
 - Installation
- Operating Expenses
 - Energy consumption
 - Maintenance
 - Production losses
 - Environmental
 - Inventory
 - Operating
 - Removal



Typical Pump Life Cycle Costs¹

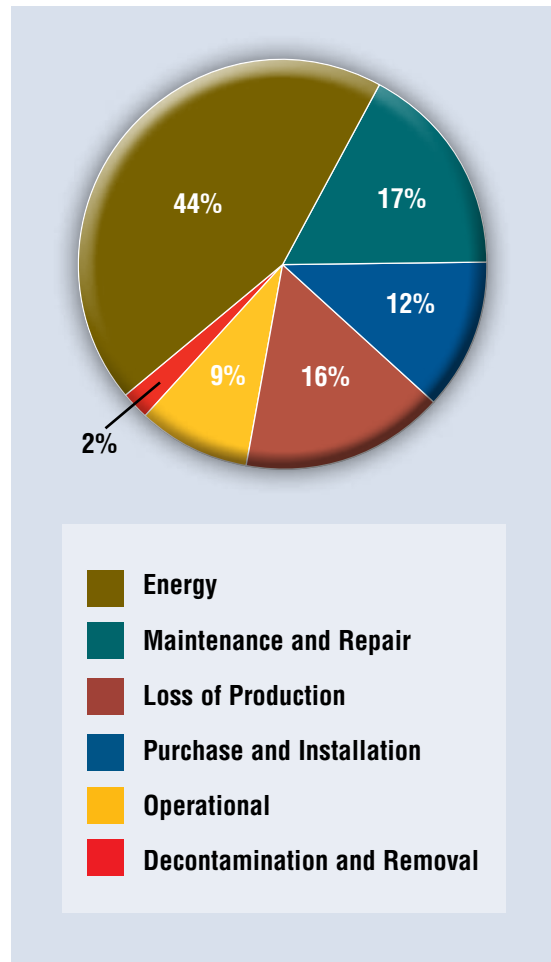

¹ While exact values may differ, these percentages are consistent with those published by leading pump manufacturers and end users, as well as industry associations and government agencies worldwide.



Innovative Life Cycle Cost Programs

New Pump Selection

FlowsERVE provides front-end consulting services that balance initial procurement cost with longer-term operational concerns, including equipment reliability and energy consumption. Proper upfront selection of a high-efficiency, high-energy pump can literally save millions of dollars in operating costs over the life of the system.

Turnkey Engineering and Field Service

FlowsERVE offers turnkey engineering capabilities to streamline capital expenses related to piping design, foundation engineering, electrical systems and instrumentation. FlowsERVE technicians can offer installation and commissioning solutions that significantly reduce installation time such as advanced laser alignment and ungrouted foundation solutions.

Energy Management

Pumping systems can comprise between 20% and 50% of energy usage in typical industrial plants and as much as 95% in pipeline systems. On behalf of its customers, FlowsERVE actively pursues hydraulic re-rates, pump upgrades and system enhancements that offer energy savings between 30% and 50% of existing levels. A typical improvement program may involve field assessments, analytical modeling and investment recommendations.

Pump Availability

FlowsERVE engineers and technicians have been specially trained to help customers analyze, diagnose and solve those issues that cause problematic pump breakdowns and unscheduled outages. Engineers are equipped to collect real-time data, review performance problems, analyze data and make recommendations that result in improved pump system availability and higher profits.

Proactive Maintenance

FlowsERVE technicians are trained to provide services that go beyond simple reactive maintenance and repair. By analyzing failure modes, FlowsERVE can offer upgrades ranging from materials and coatings upgrades to hydraulic re-rates — all aimed at increasing pump reliability.

Inventory Management

Programs that help standardize materials, maximize interchangeability and increase part and assembly availability can have a significant impact on costs associated with spare parts inventory. Asset management experts from FlowsERVE can offer customized programs that reduce inventory levels while ensuring availability of critical parts.

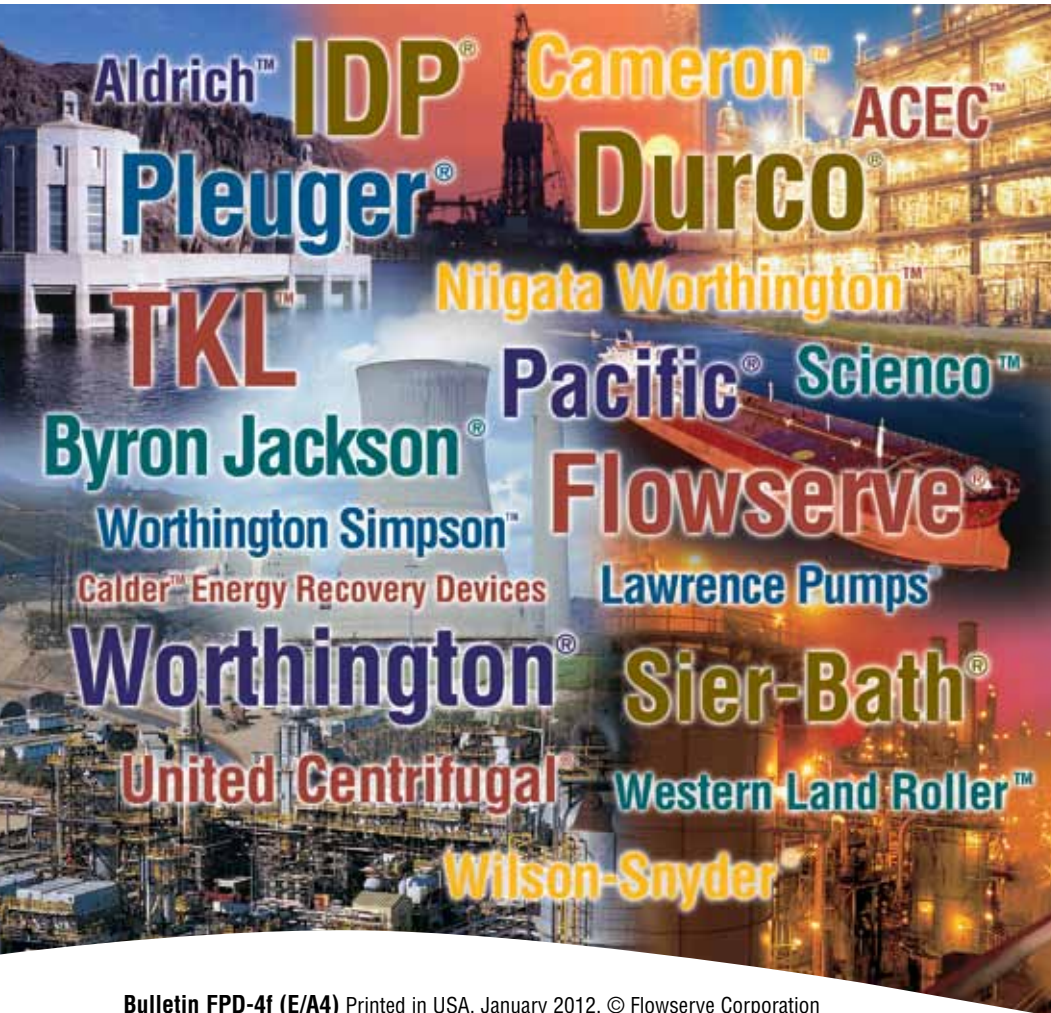

Bulletin FPD-4f (E/A4) Printed in USA. January 2012. © Flowserve Corporation

To find your local Flowserve representative:

For more information about Flowserve Corporation,
visit www.flowserve.com or call +1 937 890 5839.

USA and Canada

Flowserve Corporation
5215 North O'Connor Blvd.
Suite 2300
Irving, Texas 75039-5421 USA
Telephone: +1 937 890 5839

Europe, Middle East, Africa

Flowserve Corporation
Parallelweg 13
4878 AH Etten-Leur
The Netherlands
Telephone: +31 76 502 8100

Latin America

Flowserve Corporation
Martín Rodríguez 4460
B1644CGN-Victoria-San Fernando
Buenos Aires, Argentina
Telephone: +54 11 4006 8700
Telefax: +54 11 4714 1610

Asia Pacific

Flowserve Pte. Ltd.
10 Tuas Loop
Singapore 637345
Telephone: +65 6771 0600
Telefax: +65 6862 2329