

Outline drawings

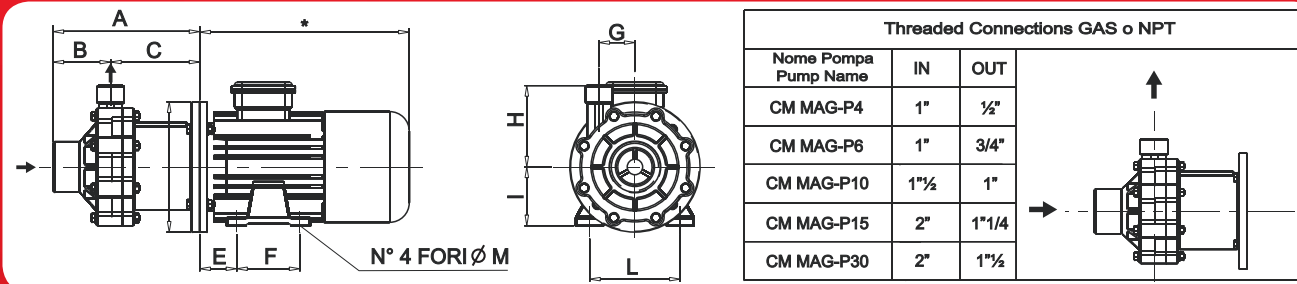

Pump Name	GR.	A	B	C	D	E	F	G	H	I	L	M
CM MAG-P4	56	114	38.5	75.5	120	36	71	34	80	56	90	5.8
CM MAG-P6	63	143	59	84	140	40	80	46	91	63	100	7
CM MAG-P10	71	180	70.8	109.5	160	45	90	44	100	71	112	7
CM MAG-P15	80	231	81	150	200	50	100	62.5	125	80	125	9.5
CM MAG-P30	90	278	91	187	200	56	100	66.5	140	90	140	10
CM MAG-P30	100/112	296	91	205	250	63	140	66.5	140	100	160	12

Performance curves

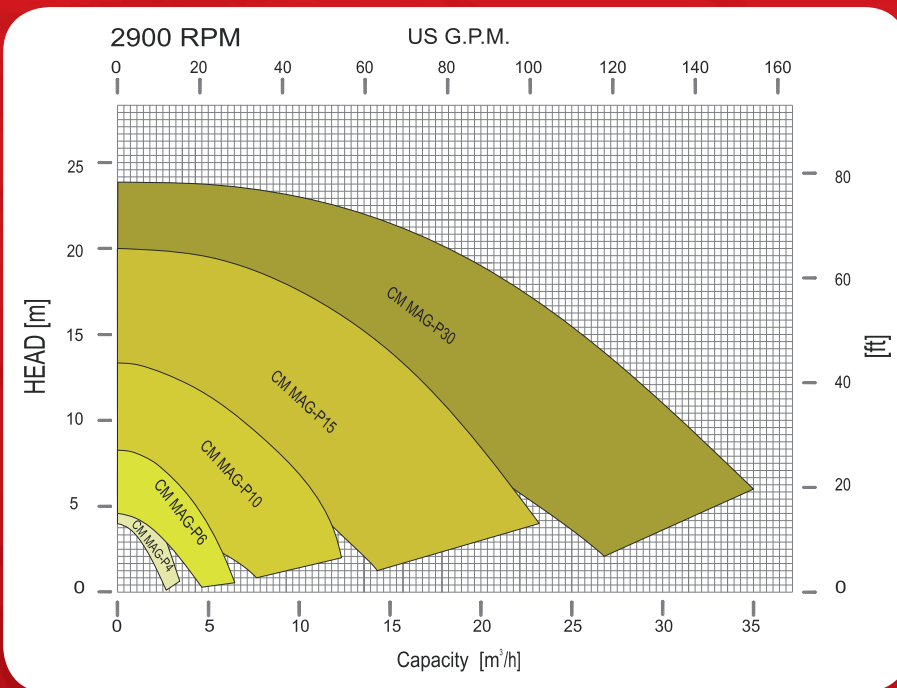

Pump construction and Operative Limits

Close-coupled drivers are conventional drivers mounted directly to pumps frame. No base, coupling or guards are required for this mounting style.

- Connections: Threaded BSP (GAS) & NPT.
- Max viscosity: 200 cSt
- Max system pressure: 5 bar
- Flow up: to 35mc/h
- Head up: to 23 m
- Temperature range: from 24 °F (-5 °C) to +194 °F (+90 °C)
- Electric motors from 1,5Kw up to 5kW

HORIZONTAL, SEALLESS PP AND PVDF CENTRIFUGAL PUMP WITH PERMANENT MAGNET DRIVE SYSTEM, NO MECHANICAL SEAL

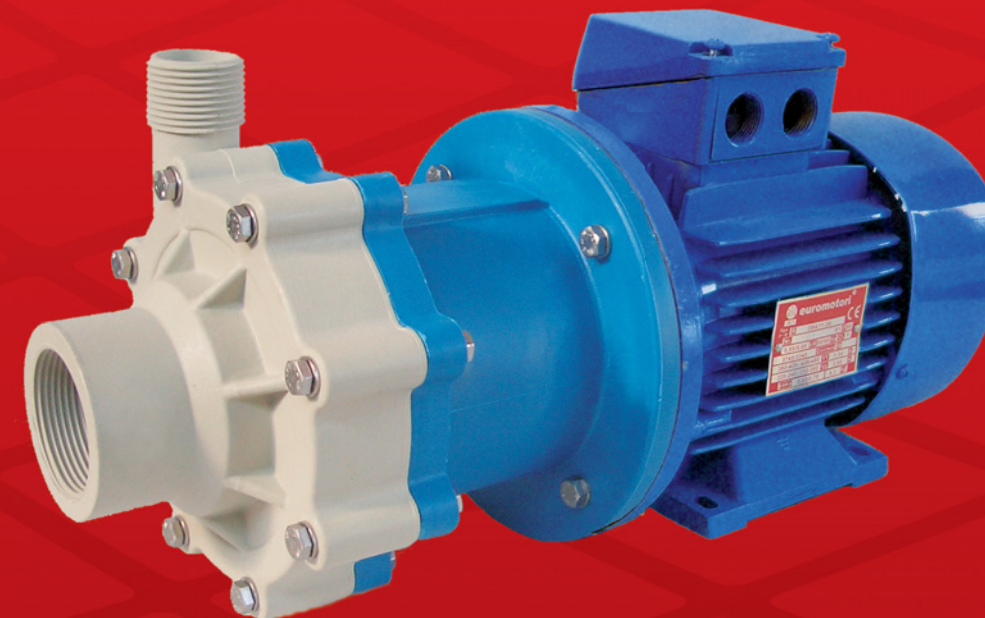

CM MAG-P

Manufactured by:



A unit of
Mischiatti
GROUP

M PUMPS s.r.l. - Via dell'Artigianato, 120
45015 Corbola (Ro) - Italy - www.mpumps.it
Tel. +39 0426 346304 - Fax +39 0426 349126

For more information please contact:



ISO 14001:2004

273

CM MAG-P Series

The separation of liquid chamber/atmosphere by means of an isolation shell is the best solution to pump aggressive chemical, high purity liquids and liquids difficult to seal.

Hermetic sealless injection moulded thermoplastic pumps are the best solution for light duty applications.

A wide range of pumps covers the different performances.



PUMP DETAILS

Making a comparison between this range of pumps and the other two M PUMPS series C MAG-P and C MAG-PL, the correct definition becomes few components (extremely easy maintenance), competitive prices, guaranteed chemical compatibility.

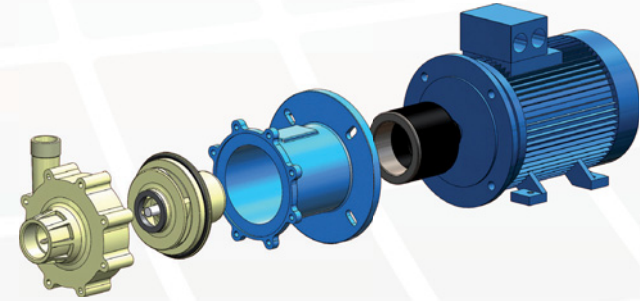

Pump casing shall be one single piece, injection moulded designs, made of GFR PP and CFR PVDF.

RWP QUICK CHANGE CARTRIDGE KIT
to guarantee an easy and fast maintenance, materials PP and PVDF.

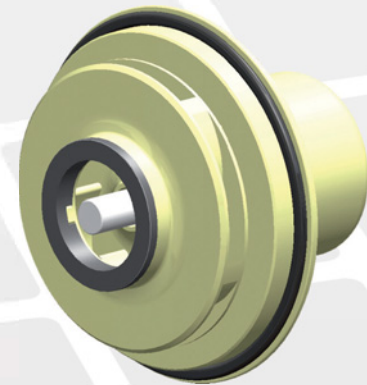

The sealing system with O-Rings prevents from leaking in the atmosphere – different materials available:

- EPDM
- VITON®

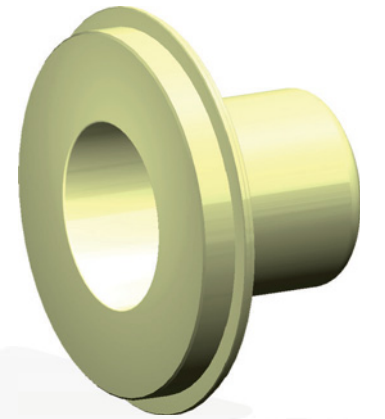
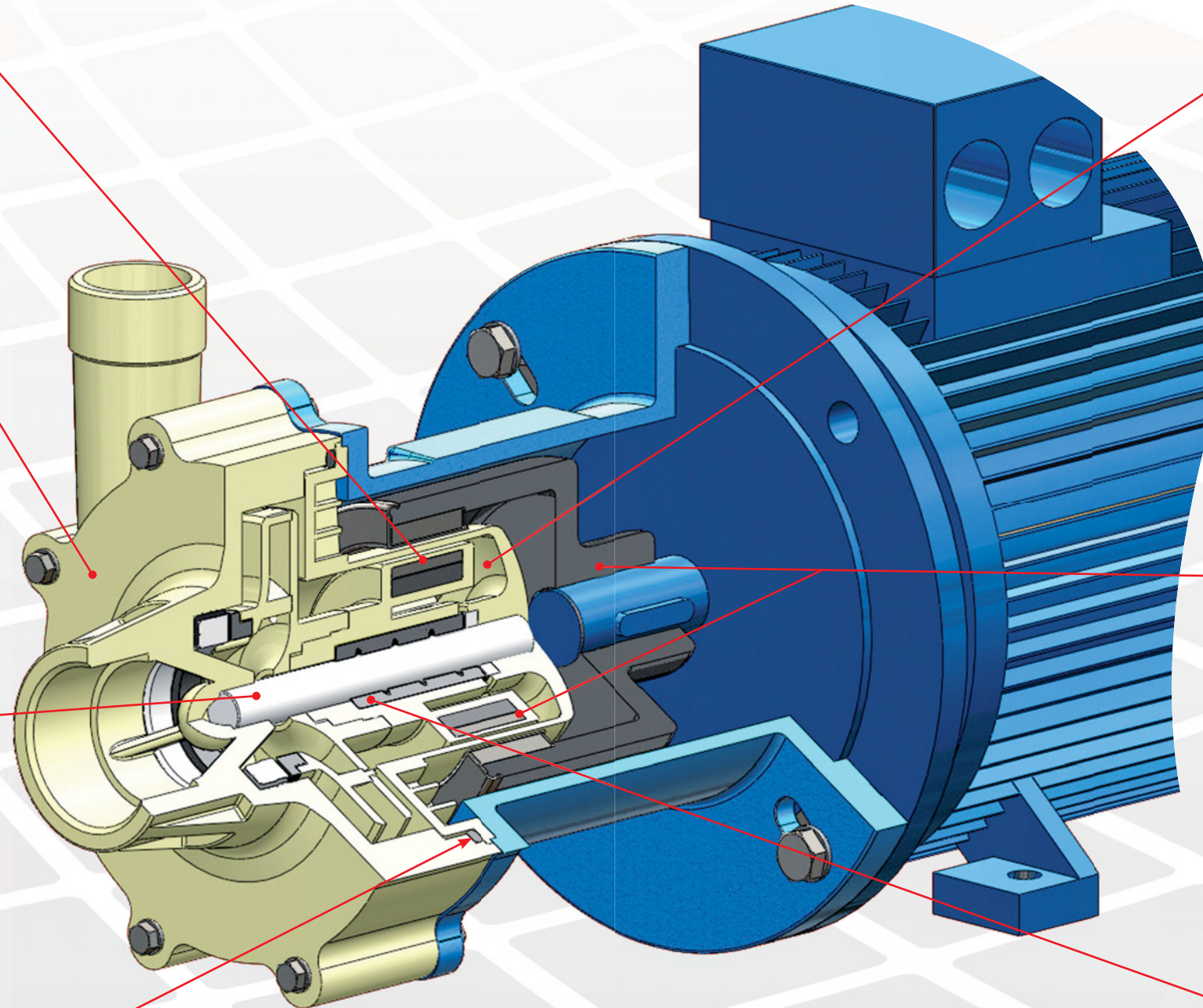

The rear shell is made of thermoplastic materials, ellipsoidal profile, zero magnetic losses, GFR PP or CFR PVDF materials.

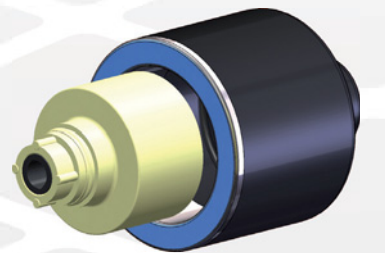

High power synchronous magnetic coupling designed by our Technical Office and with magnetic elements mechanically locked.

Rare earth guarantee the magnetic-balancing to avoid the thrust bearings wear and the heat generation.

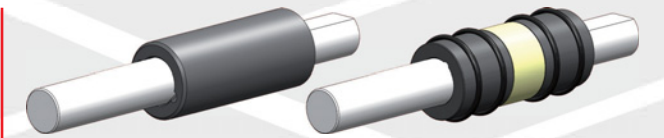

Field assembling of the product lubricated bearing arrangement does not require special tools.

The Shaft / Bearing materials are available in two different configurations to provide the best solution for each application:

- PTFEC – ALLUMINA 99,7% (standard)
- CARBON – ALLUMINA 99,7%